

HDGPS ANCHOR+[®]

Owner's Manual



RHODAN[™]
MARINE SYSTEMS

HDGPS ANCHOR+[®]

Congratulations on choosing this unique product. The Rhodan Marine Systems HD GPS ANCHOR+ will dramatically add to your angling efficiency and enjoyment.

Powerful and quiet, this precision engineered product will automatically keep your boat positioned at your chosen location or at your command, maintain the boat on a chosen route, leaving you free to concentrate on fishing.



WARNING!

READ AND UNDERSTAND ALL INSTRUCTIONS.

Failure to follow all enclosed instructions may result in personal injury or loss of warranty.

SPECIFICATIONS

Anchor Memory Locations	4
Multi-use Memory Locations (route or anchor)	8
Maximum Course Memory Length	1000+ Miles*
Thrust Rating	36V System @ 120lb
	24V System @ 80lb
	12V System @ 55lb
Operating Voltage	12V, 24V or 36V (Depending on model)
Amperage	0-42 Amps**
Recommended Breaker Rating	50 Amps
Propeller	3 Blade Weedless

*The length of a recorded route will generally be limited by the time required to physically traverse a route or the battery capacity to retrace it. The system has sufficient memory capacity to store over 1000 miles of courses.

**System current draw will vary with thrust level up to a maximum of 42 amps at 100% thrust.



TABLE OF CONTENTS

SYSTEM FEATURES	4
POWERING UP THE UNIT	5
DEPLOYING THE UNIT	6
STOWING THE UNIT	6
MODES OF OPERATION	7
1. MANUAL MODE	7
2. ANCHOR MODE	8
3. TRACK MODE	10
4. ROUTE MODE	11
APPENDIX A: GENERAL INFORMATION	12
APPENDIX B: INSTALLATION CHECKLIST	12
APPENDIX C: PHYSICAL INSTALLATION	13
APPENDIX D: ELECTRICAL INSTALLATION	16
APPENDIX E: PROPELLER INSTALLATION	18
APPENDIX F: CALIBRATIONS	19
APPENDIX G: FOB FEATURES	21
APPENDIX H: PREVENTATIVE MAINTENANCE	22
STATUS LIGHTS	24
WARRANTY	25

FCC COMPLIANCE STATEMENT

FCC ID:XA7-RMS-FOB1

This device complies with part 15 of the FCC Rules. Operation is subject to the following two conditions:

1. This device may not cause harmful interference, and
2. This device must accept any interference received, including interference that may cause undesired operation.

This device complies with FCC Rules. Changes or modifications not expressly approved by Rhodan could void the user's authority to operate the equipment.

RHODAN[®]
MARINE SYSTEMS

SYSTEM FEATURES

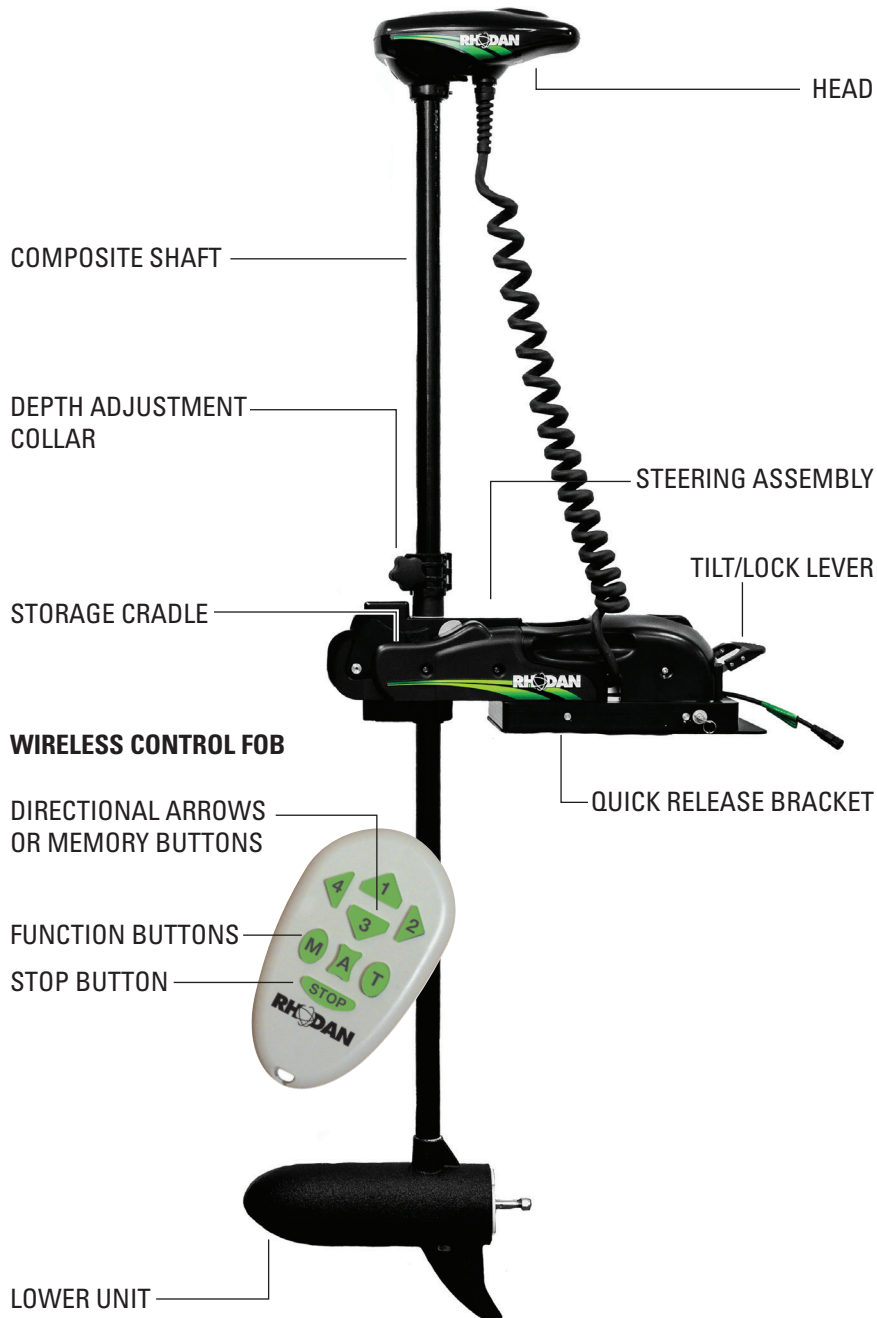

POWERING UP THE UNIT

The system is able to operate in Manual Mode immediately when powered up and deployed. The Anchor Mode and Track Mode will be available in approximately 30 seconds once the unit has acquired a GPS fix. |

- The unit will emit 2 “beeps” and status light will flash green, amber, red sequence to indicate that it is powered up.
- The unit will emit 4 rapid “beeps” and GPS status light will show steady amber or green to indicate that it has acquired a GPS fix.

The GPS accuracy will continue to improve for several minutes after being powered up. It is suggested that you apply power to the GPS ANCHOR early in the trip so that it will achieve maximum accuracy before being used. The system is equipped with a “Tilt” sensor that prevents the propeller from running in the stowed position.

BATTERY LEVEL METER

Press and hold the “STOP” button for 5 seconds to check the state of charge of the system batteries. *The system will emit between one and five beeps which define the amount of energy remaining in the batteries.*

# of Beeps	Battery Level	36V	24V	12V
5	>95%	>37.80	>25.20	>12.60V
4	80%–95%	37.26V–37.80V	24.84V–25.20V	12.42V–12.60V
3	60%–80%	36.60V–37.26V	24.40V–24.84V	12.20V–12.42V
2	40%–60%	35.70V–36.60V	23.80V–24.40V	11.90V–12.20V
1	20%–40%	34.50V–35.70V	23.00V–23.80V	11.50V–11.90V
1 Growl	<20%	<34.50V	<23.000V	<11.50V

This function will stop all thruster and steering operations and use the precision voltage reference of the system to determine the battery’s remaining charge. State of charge levels are based on voltage to charge references for ideal lead acid batteries from leading battery manufacturers.



DEPLOYING THE UNIT

Loosen the depth adjustment collar and slide it up the shaft to a position that will give the desired motor depth. Firmly hand tighten the adjustment knob to secure the collar.



Step on the Tilt/Lock Lever and slide the motor forward until the lower unit is clear of the storage cradle.



Carefully tilt the unit forward and lower the motor until the depth adjustment collar is engaged with the steering bosses. The Tilt/Lock Lever can be released as soon as the motor begins to tilt. Once the unit is fully deployed, verify that the lever has fully returned to its up and locked position.



STOWING THE UNIT

Step on the Tilt/Lock Lever. Grasping the head of the unit, pull it up and then back until the lower unit rests securely in the storage cradle. Release the Tilt/Lock Lever and verify that it returns fully to its up and locked position. **Slide the depth adjustment collar down until it is in contact with the steering bosses, then very firmly hand tighten the adjustment knob to secure the unit.** Done properly the unit cannot deploy.



WARNING! Failure to secure the unit with the depth adjustment collar when stowed can result in accidental deployment during extremely rough pounding seas which will not be covered by the warranty.

MODES OF OPERATION

1. MANUAL MODE

The system will automatically be in manual mode when placed in the deployed position or the **"M"** or **"STOP"** buttons are pressed.

 *The unit will emit 1 "beep" to indicate that it has entered Manual Mode.*

In the **Manual Mode** the GPS ANCHOR system behaves much like a conventional trolling motor, by allowing the user to control the direction and thrust level using the directional controls on the wireless fob.



THRUST

The system is equipped with 32 forward and 16 reverse speeds. Momentarily pressing the Up-Arrow or Down-Arrow buttons will increment the thrust level accordingly. Holding the Up-Arrow or Down-Arrow buttons will cause the thrust level to ramp until the maximum level is reached or the button is released. It will take 4 seconds for the system to ramp from 0 to 100% thrust or vice versa.

 *The unit will emit 1 "beep" when it reaches 100% forward thrust, 0% thrust or 100% reverse thrust.*



STEERING

Pressing the Left-Arrow or Right-Arrow buttons will cause the trolling motor to turn left or right, respectively. The steering travel is limited to avoid wrapping up the system power cord.



2. ANCHOR MODE

To place the system in Anchor Mode, press the button with the “A” symbol on the wireless fob. The system will instantly lock in the anchor coordinates and begin maintaining position.



🔊 / The unit will emit 1 “beep” to indicate that it has entered Anchor Mode.

🔊 / The unit will emit two “growls” then exit this mode if there is no GPS fix

The Anchor Mode automatically controls the steering and thruster speed to maintain the position of the boat’s bow, acting as a “Virtual Anchor”.

⚠️ **The boat will slowly weathervane around the thruster and the bow will generally come to rest pointed into the disturbing wind or current. It is recommended that the boat be slowed or stopped prior to anchoring to minimize overshoot.**

ADJUSTING THE ANCHOR LOCATION (JOGGING)

Pressing any of the directional controls on the wireless fob (Up, Down, Left, or Right) moves (jogs) the “Anchor Location” in precise 5-foot increments relative to the boat’s heading. For example, pressing the Right-Arrow once moves the “Anchor Location” 5-feet to the right of the boat’s bow.



🔊 / The unit will emit 1 “beep” for each increment the Anchor location is moved.

⚠️ **The embedded system computer will be operating the trolling motor causing the bow of the boat to move as needed to maintain its location in this mode. Unexpected movement of the boat may tend to unbalance you. Be cautious until you have become familiar with the system dynamics.**

STORING (OR OVERWRITING) AN ANCHOR SITE

From any mode, simultaneously press and hold the “A” button and one of the directional buttons for 5 seconds. The buttons can then be released and your boat will be anchored at this newly recorded site.



🔊 / The unit will emit a 1 second “beep” to indicate that the anchor site has been successfully saved.

RECALLING A STORED ANCHOR SITE

From any mode, while holding down the “A” button, press and release the appropriate directional button. The “A” button can then be released and your boat will navigate in a straight line directly to that location and anchor at the selected, previously recorded site.



🔊 / The unit will “beep a tune” (multiple consecutive beeps) to indicate that the anchor site has been successfully retrieved.

🔊 / The unit will emit two “growls” and exit if the memory location is empty or the boat is not within 1 mile of a memorized location.

⚠️ **When recalling a stored anchor site if you hold the buttons for more than 5 seconds you will over-write that existing memory location with the boat’s present location, erasing it.**

⚠️ **The system will calculate a beeline to the selected anchor site. Make sure there are no obstructions between you and the anchor site prior to recalling a location.**

RECALLING LAST ANCHOR SITE

From any mode, press and hold the “A” button for 5 seconds. The “A” button can then be released and your boat will navigate directly to the last anchor location used.



🔊 / The unit will “beep a tune” (multiple consecutive beeps) to indicate that the anchor site has been successfully retrieved.

🔊 / The unit will emit two “growls” and exit if there is no active last memory location or the boat is not within 1 mile of the previous location.

3. TRACK MODE

To place the system in Track Mode, press the button with the “T” symbol on the wireless fob. The Track Mode automatically locks in the thruster’s current heading and controls the steering to maintain a constant track, acting as an “Autotrack” to compensate for wind or current disturbances. The operator can adjust the speed or track heading by using the directional controls on the wireless fob.



The unit will emit 1 “beep” to indicate that it has entered Track Mode.

The unit will emit 2 “growls” and exit this mode if there is no GPS fix.

The direction the boat is pointed when this mode is selected will become the “Track Course”. The thruster will pull the bow of the boat along this course in a straight line. The boat itself may seem to point somewhat “off track” due to cross-wind or cross-track currents.

ADJUSTING THE TRACK SPEED

The unit will maintain its previous speed if Track Mode is selected from the Manual Mode. Otherwise, the unit will gradually ramp to 40% forward speed to maintain the track. Pressing the Up-Arrow button increases the thruster’s forward speed. The Down-Arrow button decreases the thruster’s forward speed. Reverse operation is disabled in this mode.



The unit will “beep” when the thruster reaches 100% forward speed or when it is stopped.

ADJUSTING THE TRACK COURSE

The “Track Course” may be adjusted to steer the thruster to the desired new heading by pressing the Left or Right Arrow buttons on the wireless fob.



In this mode, the steering is automatic, but the thrust level is user selected. In extreme wind or current it is necessary for the user to select a speed setting with adequate thrust to overcome the disturbances and remain “on-track”.

4. ROUTE MODE

STORING (OR OVER WRITING) A ROUTE

From any mode, simultaneously press and hold either the “M” or “T” button and one of the directional buttons for 5 seconds. The buttons can then be released and the system will now be in the function corresponding to the button you selected “M” or “T”. The system is now recording your route.



The unit will emit a 1 second “beep” to indicate that the route is being recorded.

You can now navigate along your desired course, switching at will between manual and track modes. The recording will terminate when you press “STOP” or “A”.



The unit will emit a 1 second “beep” to indicate that the route has been successfully saved.

Should you wish to record an anchor site using the “M” or “T” memory these locations, simply hit “STOP” or “A” as soon as the path begins to record, thus recording a path of zero length. A route can also be recorded at higher speeds with the system in the stowed position. Simply use the route storing procedure above and the system will accurately record your route at speeds of up to 60 knots. For safety, the thruster and steering motors will be disabled as long as the system is in the stowed position.

RECALLING A STORED ROUTE:

From any mode, while holding down the “M” or “T” button, press and release the appropriate directional button.



The unit will “beep a tune” (multiple consecutive beeps) to indicate that the route has been successfully retrieved.

The unit will emit two “growls” and exit if the memory location is empty or the boat is not within 1 mile of a point on the route.

The system will navigate directly to the nearest point on the route and then travel to the most distant end, anchoring when it arrives. At any time while retracing a route you can reverse the direction of travel by simply repeating the same recall command.

The unit will “beep a tune” to indicate that the boat is arriving at the end of the recorded route.

When recalling a stored route if you hold the buttons too long you will over-write that existing route memory location with the boat’s present location, erasing it and begin recording a new route.

The system will calculate a beeline to the nearest point on the route. Make sure there are no obstructions between you and the route prior to recalling it.

RHODAN
MARINE SYSTEMS

APPENDIX A: GENERAL INFORMATION

 It is recommended that a trained technician install the GPS Anchor. Contact Rhodan Marine Systems for a list of approved installers. Improper installation can lead to poor performance, injury or even death. It is the responsibility of the installer to verify proper installation.

 DO NOT connect the HD GPS ANCHOR+ to a power source until installation is completed.

 The HD GPS ANCHOR+ utilizes sensors which will likely be affected by nearby magnetic fields. DO NOT install unit with or near anything that produces a magnetic field (steel, magnets, etc.)

APPENDIX B: INSTALLATION CHECKLIST

- PHYSICAL INSTALLATION
- ELECTRICAL INSTALLATION
- PROPELLER INSTALLATION
- ALIGNMENT CALIBRATION
- COMPASS CALIBRATION (OPTIONAL)

APPENDIX C: PHYSICAL INSTALLATION

TOOLS REQUIRED

- 1/4" Drill Bit (included) and Drill
- Marking Pen or Pencil
- #3 Phillips Screwdriver
- Level (optional)

 The following process is of moderate difficulty. Should you not feel comfortable performing the steps listed below, we recommend that you contact an authorized installer to complete this process for you.

Prior to beginning the installation process, give some consideration to the desired mounting location. Most commonly these systems are mounted on the bow at a slight angle to the keel so that the shaft of the motor does not obstruct the foredeck while stowed. The following instructions are based on that approach. Should your particular installation differ, please feel free to contact Rhodan Marine for additional guidance or recommendations.

There are two types of quick release brackets provided on the HD GPS anchor. Determine which bracket your system has and follow the appropriate instruction set for that model.

1. With system in the stowed and locked position place it so that the base rests on the deck, approximately in the desired mounting position. Rotate the system to the appropriate angle relative to the boat. Generally speaking you will want to position the head of the unit so that it is protected by the rub-rail, but off to one side to free up as much space on the foredeck as possible. Once positioned in this manner, use your marking pen to draw a line on the deck along one side of the quick release bracket. This will provide a reference to position the motor at the correct angle in the next phase.



2. Deploy the system so that it is locked in the operational position.

 The system can be quite awkward to handle at this stage, so it may be desirable to have a second person assist you with this step.

3. Align the quick release bracket with the mark on the deck from the previous step. Shift the motor along that line until there is approximately 1" of clearance between the shaft of the system and the rub-rail of the boat. (In bow mount installations this is generally the critical clearance point. Refer to the table below for other recommended clearances.) Once in position, use the marking pen to draw a line on the deck around the back of the quick release bracket.

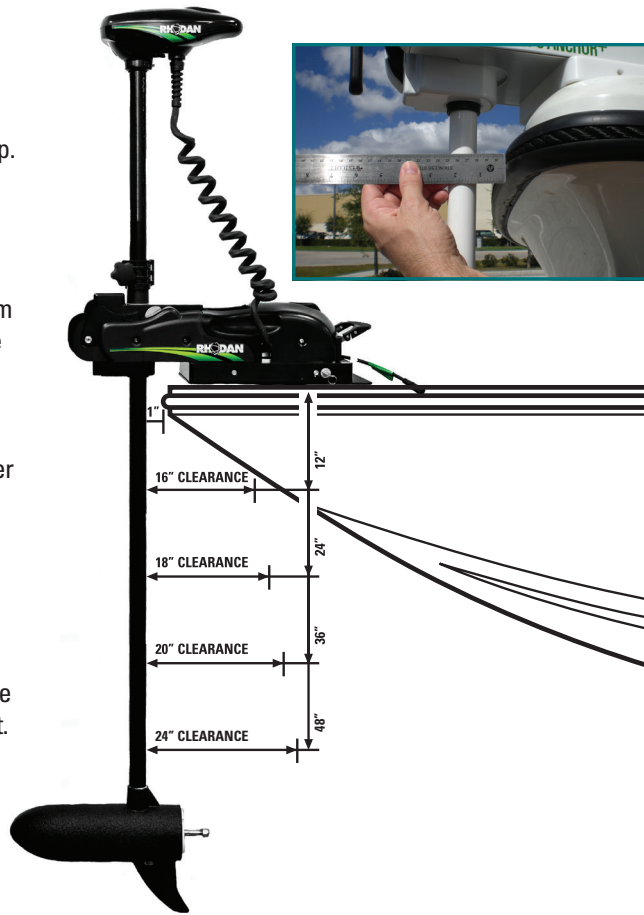

4. Remove the system from the boat. Place the included mounting template on the deck and align it with the marks made in the previous steps. Use your pen to mark the locations of the mounting holes on the deck.

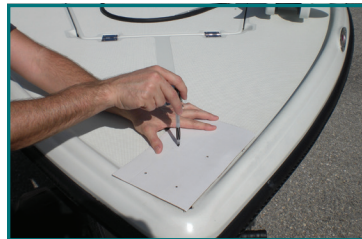

5. Once the holes are marked, verify that there are no wires or other components beneath the mounting hole locations that might be damaged. Drill a 1/4" hole at each of the four locations marked.



6. Place the lower half of the quick release bracket on the deck and align with the holes drilled in the previous step. Insert the six 1/4"-20x3" mounting screws from the included hardware kit (note: it is helpful to apply a small amount of lubricant to the threads of the screws prior to insertion). At this point check to see that the base is sitting flat on the deck. If there are any gaps, or if you wish to level the base to the boat (optional), install washers or other spacers (not provided) as needed.



7. Once leveled, install fender washer and lock nut onto the mounting screw and tighten to a torque of 5 ft-lbs.

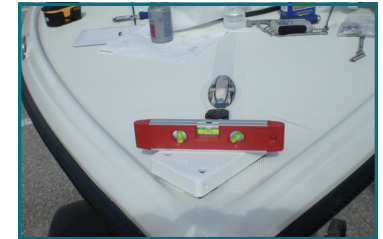

This completes the physical installation. Refer to the following steps for electrical installation and calibration.

APPENDIX D: ELECTRICAL INSTALLATION

The HD GPS ANCHOR+ requires one 12V battery for the 12V units, two 12V battery in series for the 24V units and three 12V battery in series for the 36V units.

⚠ Batteries produce and contain harmful materials that may result in personal injury and/or property damage if improperly used. Refer to your battery manufacturer's guidelines for charging, discharging, storage and care instructions.

⚠ Be sure all switches/circuit breakers are in the OFF position and fuses are removed when making battery connections. Failure to do so may result in personal injury and/or property damage.

⚠ DO NOT connect the trolling motor batteries to any other device, including the main outboard engine.

⚠ Verify that all conductors and connectors are rated for at least 50 Amperes and 36VDC, 24VDC or 12VDC (depending on model). All circuits MUST be protected using a 50A fuse or circuit breaker in series with the positive lead. Failure to do so may result in personal injury and/or property damage.

LUG (BASIC) INSTALLATION

Your GPS Anchor system is provided with a factory installed 6' power cord with 5/16" ring terminals for connection to breaker/battery terminals or power lugs. Please note that it is mandatory to install a fuse or breaker protection for the system circuit. This protection should be rated for 50A, 36V, 24V or 12V (depending on model). If your boat is already wired with a 36V, 24V or 12V (depending on model) power system with appropriate circuit protection, simply connect the white wire to the positive lug and the black wire to the negative lug. Should your boat use a trolling motor plug or not have a 36V, 24V or 12V (depending on model) trolling motor circuit, please refer to additional instructions below or contact an approved system installer.

PLUG INSTALLATION

If your boat is already wired with a 36V, 24V or 12V (depending on model) trolling motor battery system it may be necessary to install a plug on the end of the main power conductor in order to work with your boat.

⚠ The following process is of moderate difficulty. Should you not feel comfortable performing the steps listed below, we recommend that you contact an authorized installer to complete this process for you.

There are many different plugs on the market, but generally it is possible to obtain the appropriate plug from your local boating supply store. Please make sure that the plug you install is rated for 50A, 36V, 24V or 12V (depending on model). Should you have difficulty locating the appropriate plug, please contact Rhodan Marine Systems, and we will do our best to assist you.

Once the appropriate plug is obtained, it will need to be installed on the power cord. Depending on the location of the socket relative to your system it may be appropriate to trim the main power conductor to a shorter length. If shortening the power cable, be sure to leave adequate length to complete the connection to the plug and allow for the plug to be inserted with a small amount of slack remaining. Generally you should have 6" to 12" of slack in the cable when plugged in.

Using a volt meter, determine the positive 36V, 24V or 12V (depending on model) and ground (negative) terminals on the socket and plug. Following the instructions provided with the plug, connect the white power wire to the positive 36V, 24V or 12V (depending on model) terminal and the black power wire to the negative terminal.

When complete, reinstall any fuses or turn on your circuit breaker and insert the plug into the socket. At this point you should hear the system beep indicating that it is getting power.

COMPLETE ELECTRICAL INSTALLATION

If your boat is not already equipped with a 36V, 24V or 12V (depending on model) battery power system it will be necessary to install one.

⚠ This process is of moderate difficulty and should only be attempted by experienced technicians. We recommend that you contact an authorized installer to complete this process for you.

36 VOLT TROLLING MOTOR BATTERY SYSTEM

A 36 volt trolling motor battery system will generally consist of three, 12 volt deep cycle batteries, #6 (or larger for long runs) power conductors, a 36V, 50A rated circuit breaker, a 36V, 50A rated receptacle, and optionally a permanently installed 36V battery charger as per the following wiring schematic.

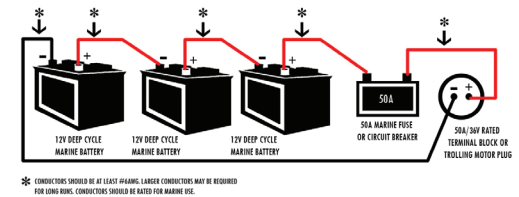

24 VOLT TROLLING MOTOR BATTERY SYSTEM

A 24 volt trolling motor battery system will generally consist of two, 12 volt deep cycle batteries, #6 (or larger for long runs) power conductors, a 24V, 50A rated circuit breaker, a 24V, 50A rated receptacle, and optionally a permanently installed 24V battery charger as per the following wiring schematic.

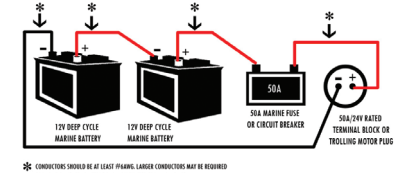

12 VOLT TROLLING MOTOR BATTERY SYSTEM

A 12 volt trolling motor battery system will generally consist of a 12 volt deep cycle battery, #6 (or larger for long runs) power conductors, a 12V, 50A rated circuit breaker, a 12V, 50A rated receptacle, and optionally a permanently installed 12V battery charger as per the following wiring schematic.

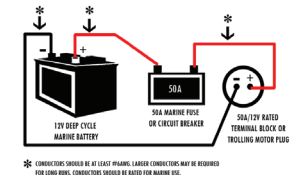

If you plan to attempt a complete installation yourself, please feel free to contact Rhodan Marine Systems for additional guidance and information.

RHODAN
MARINE SYSTEMS

APPENDIX E: PROPELLER INSTALLATION

INCLUDED

- Three Bladed Propeller
- Shear Pin
- Propeller Nut
- Propeller Washer



Always verify that the trolling motor power is disconnected before installing or cleaning the propeller. Failure to do so may result in personal injury.



Never strike any part of the motor with a hammer. This may cause damage to the motor armature, which is not covered by the warranty.

INSTALLING THE PROPELLER

1. Install the shear pin in the hole near the end of the propeller shaft.
2. Slide the propeller onto the propeller shaft, taking care to ensure that it is properly engaged onto the shear pin.
3. Install the washer and propeller nut on the propeller shaft.
4. Tighten the propeller nut using a 9/16" socket to 5 ft-lbs.
5. Be sure to periodically check the prop nut to ensure it is tight.

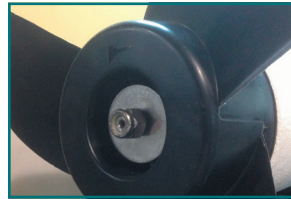

APPENDIX F: CALIBRATIONS

CENTERING CALIBRATION

Note: This procedure is required and is normally only completed once at the time of the installation. It should also be performed every time the system is transferred to another boat or after a compass calibration.

1. Power up the system and deploy it using the depth collar to adjust the height so that the motor can steer without any obstructions.
2. Press the 'M' button to enter Manual Mode. Please note that the system is in an operational mode: Stay a safe distance away from the propeller to avoid injury.
3. Using the left and right arrows (or manually rotating the head of the thruster), steer the unit so that it is aligned with the keel of the boat (pointing straight ahead with the propeller facing the stern of the boat).
4. Press and hold the up and down arrow simultaneously for 5 seconds until the system beeps.
5. The system will return to Manual Mode.
6. To verify that the system has been "centered", press the "STOP" button. The system will automatically steer to the centered position.

The accuracy of the steering calibration will impact the system's performance. Care must be taken to ensure that the thruster is aligned as accurately as possible (ideally within 1 or 2 degrees) during this calibration.

COMPASS AUTO-CALIBRATION (Recommended)

Note: Performing a compass calibration procedure is recommended as part of the installation process to improve the accuracy of the GPS Anchor. It will account for magnetic errors that can occur if the system is mounted close to other metallic objects (i.e. cleats, steel fasteners, etc.) which may cause the system functions to misbehave.

1. The boat must be in the water to perform this calibration. Make sure that there are no obstructions nearby (docks, pilings, other boats, etc.) and that the water is fairly calm.
2. Power up the system and deploy it using the depth collar to adjust the height so that the motor can steer without any obstructions.
3. Press the 'M' button to enter Manual Mode. Please note that the system is in an operational mode: Stay a safe distance away from the propeller to avoid injury.

4. Using the left and right arrow buttons, steer the unit so that it is pointing to either side (roughly 90° to the keel).
5. Press and hold the Manual 'M' and Anchor 'A' buttons down simultaneously for 5 seconds until the system beeps.
6. The motor will now automatically steer to the right and ramp up the thrust causing the boat to begin rotating. The boat will complete (2) full rotations and then the system will beep to indicate that the calibration is complete.
7. The system will return to Manual Mode.
8. It is required that the Centering Calibration is now performed.

COMPASS MANUAL CALIBRATION

1. The boat must be in the water to perform this calibration. Make sure there are no obstructions nearby (docks, pilings, other boats, etc.) and that the water is fairly calm.
2. Power up the system and deploy it using the depth collar to adjust the height so the motor can steer without any obstructions.
3. Press the Manual 'M' button to enter Manual mode. Please note the system is in an operational mode. Stay a safe distance away from the propeller to avoid injury.
4. Using the left and right arrow buttons steer the unit so that it is aligned with the keel of the boat (pointing straight ahead with the propeller facing the stern of the boat.)
5. Using another means of propulsion (main engine, paddle, etc.) begin to continuously rotate the boat in a tight circle at a rate of one full revolution every 20-30 seconds.
6. Press and hold the Manual 'M' and Track 'T' buttons down simultaneously for 5 seconds until the system beeps.
7. After the system has beeped or the boat has completed up to 2 revolutions the calibration is complete.
8. The system will return to Manual Mode. The rotation may now be stopped.
9. A centering calibration may also need to be performed again to center the motor with the keel depending on the new compass calibration.

APPENDIX G: FOB FEATURES

REPLACING A FOB BATTERY



The batteries in the wireless FOB should be capable of lasting a full fishing season or longer under normal usage conditions. If your system is powered up yet fails to respond to a FOB, or if you noticed decreased wireless range, try replacing the battery.

1. Using a #1 phillips screwdriver, remove the two screws on the back of the fob.
2. Separate the fob sections
3. Remove the rubber membrane and the circuit board from the back half of the fob shell.
4. Slide the battery out of its holder on the back of the circuit board and replace with a new CR2032 battery. Be sure to position the battery with the Positive side away from the board.
5. Reinstall the circuit board in the back half of the fob shell, taking care to make sure it is properly positioned in the shell.
6. Place the rubber membrane over the lip on the back half of the fob shell and press into place.
7. Place the front half of the fob shell over the rubber membrane and press into place. Verify that all buttons are properly positioned within their opening and function correctly.
8. Reinstall the two screws into the fob shell, taking care not to over-tighten the screws.

PROGRAMMING A NEW WIRELESS CONTROL FOB

1. Power up the unit in the stowed position and wait for the two power up beeps.
2. Deploy, stow and re-deploy the unit prior to pressing any fob buttons. System will emit 2 beeps each time when it recognizes the new stow/deployed position.
3. The unit will begin "beeping" indicating that it is ready to learn new wireless controls.
4. Hold the "STOP" button until the system emits as long beep and then stops beeping.
5. The new fob had now been learned by your system and is ready to be used.



Warning, do not attempt to stow the unit until it has stopped beeping.

ERASING ALL FOBS FROM MEMORY

1. Power the unit up in the stowed position
2. Deploy, stow and re-deploy the unit prior to pressing any fob buttons.
3. The unit will begin "beeping" indicating that it is ready to learn new wireless controls from the step above. System will emit 2 beeps each time when it recognizes the new stow/deployed position.
4. Within 20 seconds (while the system is still beeping) stow and deploy the system once more.
5. The system will sound a long beep indicating that all fobs have been erased from memory.



If this step is being performed because of concerns about a defective fob, it will be necessary to remove the batteries from all fobs in question prior to completing this process.

APPENDIX H: PREVENTATIVE MAINTENANCE



Trolling motor must be disconnected from power source (ie. trolling motor plug or circuit breaker) when charging or stored at end of day. Failure to power down can result in damage that is not covered under warranty.



It is recommended that the following steps be taken after each use. Adhering to these recommendations can greatly increase the life of the unit. Failure to properly maintain the unit may void the warranty and can result in system damage, personal injury, and property damage.

AFTER EACH USE

1. Remember to unplug and remove ALL electrical power sources from your Rhodan HD GPS Anchor+ prior to conducting maintenance or charging your battery system. NEVER leave your Rhodan HD GPS Anchor+ system UNATTENDED while connected to electrical power or not in use.
2. Wash down with fresh water and dry with a clean, soft cloth. *DO NOT use a pressure washer or jet stream of water to wash down the unit*
3. Ensure the prop is free and clear of any seaweed, fishing line, or debris. This will damage the seal and result in lower unit failure if not removed. Use a small amount of Vaseline or marine-grade lubricant on the prop shaft. *Never use power tools to remove or install props. Hand wrench only. Use caution removing and installing props as they have sharp edges. We recommend using hand protection (gloves) when handling the prop/lower unit* Use caution to NOT drop the prop pin. Torque the locking prop nut to 5 ft-lb when reinstalling.

MONTHLY

1. Lubricate the shaft with Vaseline or a clear marine-grade lubricant 8-12" above lower unit connection to the shaft.
2. Wipe down the data cable and power cable with a UV protectant.
3. Inspect cables for any broken cable insulation. Repair as needed with an approved electrical tape.
4. Inspect/clean battery terminals for corrosion. Check connections for tightness.
5. Ensure your batteries are being charged on a regular basis. Low battery voltage will affect the performance of your Rhodan HD GPS Anchor+ unit. *NEVER charge the battery system while your Rhodan HD GPS Anchor+ is connected*
6. Remove the side covers and rear cover on the base unit with a Phillips screw-driver. Inspect electrical connections and cradle linkage for corrosion. Clean if necessary. Lubricate cradle linkage with Vaseline or an aerosol marine-grade lubricant on moving parts.
7. Remove the head cover and inspect for corrosion, water, and component wear/power connections. Wipe clean and dry using water only.
8. DO NOT overtighten the cover bolts during the reinstallation process.

ANNUALLY OR WHEN MOVING FROM VESSEL TO VESSEL

1. Check FOB battery voltage. Proper voltage is 3.2V. Replacement battery part number is CR2032. Coat the edge of the green FOB membrane with Vaseline to provide a proper water-resistant seal. DO NOT over-tighten the FOB Shell screws. *Recommended Annually*
2. Perform Compass Manual Calibrations. See Owners Manual for details.
3. Perform Centering Calibrations. See Owners Manual for details.
4. Check mounting brackets for broken or loose fasteners or cracks.

STATUS LIGHTS

Your HD GPS ANCHOR is equipped with 3 status indicator lights to confirm normal operation or assist in troubleshooting. The table below summarizes the meaning of the various lights.

GPS STATUS LIGHT (LEFT LED)

- **Green:** DGPS Lock (Best Performance)
- **Amber:** GPS Lock (GPS modes will function, but signal is not optimal, verify that the system has a clear sky view)
- **Flashing Amber:** No GPS Lock (GPS signal lost or not found, GPS modes will not function, verify that system has a clear sky view, if light remains flashing for more than 5 minutes cycle power to system. If problem persists, contact Rhodan Marine)
- **Red or Flashing Red:** GPS Fault has been detected (GPS modes will not function). Cycle power on system. If problem persists, contact Rhodan Marine.

BATTERY STATUS LIGHT (CENTER LED)

- **Green:** Battery Voltage is Good (>12.0v per battery)
- **Amber:** Battery Voltage is at low end of normal range (11.5V to 12.0V per battery)
Battery may be below 50% capacity:
 - If light remains amber after charging there may be an issue with battery/wiring/or charging systemIf light turns amber at high thrust levels:
 - Propeller may be fowled
 - There may be an issue with the battery or wiring on the boat.
- **Red:** Battery Voltage is too low (<11.5v per battery)
Battery may be fully discharged (less than 20% capacity remaining):
 - If light remains red after charging there may be an issue with battery/wiring/or charging systemIf light turns red at high thrust levels:
 - Propeller may be fowled
 - There may be an issue with the battery or wiring on the boat.

SYSTEM STATUS LIGHT (RIGHT LED)

- **Green:** System is operating Normally
- **Amber:** System is receiving a command from the wireless fob. It is normal for this light to change to amber any time a button is pressed on the remote. This can be used to verify proper communication from the fob. Light should return to green if fob buttons are released.
- **Red or Flashing Red:** System has detected a fault condition. Cycle power to system and allow about 30 seconds for it to reboot. If problem persists, please contact Rhodan Marine.

WARRANTY

This Limited Warranty ("Warranty") is a voluntary manufacturer's warranty by Rhodan Marine Systems of Florida, LLC. This Warranty applies to you only if you are the original purchaser of a Rhodan Marine Systems trolling motor (the "Product") and you purchased the Product directly from Rhodan Marine Systems or an authorized Rhodan Marine Systems dealer. This Warranty applies only to the original purchaser and is not transferable.

THIS LIMITED WARRANTY GIVES YOU SPECIFIC LEGAL RIGHTS AND YOU MAY ALSO HAVE OTHER RIGHTS, WHICH VARY FROM STATE TO STATE.

OUR RESPONSIBILITY FOR DEFECTIVE GOODS IS LIMITED TO REPAIR OR REPLACEMENT AS DESCRIBED BELOW IN THIS WARRANTY STATEMENT.

IMPORTANT SAFETY INFORMATION

Before your first use of the Product, please read the Owner's Manual provided with the Product. They contain important safety information and information about installation, use, maintenance and stowing. It is your responsibility to ensure that the Product is properly installed, all functional parts are adjusted properly, subsequent normal maintenance services and adjustments necessary to ensure safe operation are properly made and the Product is properly stowed.

WHAT DOES THIS LIMITED WARRANTY COVER?

Rhodan Marine Systems warrants that the Product, when properly installed, used, maintained and stowed in accordance with the Owner's Manual, will be materially free of manufacture defects for a period of 2 years from the date of original purchase of the Product. Rhodan Marine Systems will either repair the defective part(s) or, at Rhodan Marine Systems' option, replace the defective part(s) with the new or refurbished part(s), at Rhodan Marine Systems' discretion, free of charge. Inventories are not permanently maintained, therefore the exact replacement may be unavailable. Rhodan Marine Systems may also choose to replace the Product with an equivalent product if improvements have been made. Rhodan Marine Systems is constantly improving the Product and may choose to utilize improved designs on the warranty repairs.

THE WARRANTY PERIOD IS NOT EXTENDED IF WE REPAIR OR REPLACE THE PRODUCT. WE MAY CHANGE THE AVAILABILITY OF THIS LIMITED WARRANTY AT OUR DISCRETION, BUT ANY CHANGES WILL NOT BE RETROACTIVE.

WHEN DOES THIS LIMITED WARRANTY NOT APPLY?

This Warranty is void and does not apply, meaning we will not provide any warranty coverage, under any of the following circumstances:

1. Normal wear and tear.
2. Shipping Damage.
3. Cosmetic damage.
4. Corrosion.
5. Intentional damage or misuse or abuse of the Product.



6. Damage caused by acts of God, invasion or acts of war or terrorism, natural disasters or environmental reasons.
7. Failure to follow all instructions in the Owner's Manual, including, without limitation all installation, maintenance and stowing instructions.
8. Accidents.
9. Unauthorized repair or modifications.
10. The introduction of foreign objects into the Product.
11. Third party theft or vandalism.
12. Any cause other than normal use and operation of the Product in accordance with our manufacturer's specifications, instructions, or Owner's Manual.

This Limited Warranty does not apply to Products purchased outside of the U.S. Rhodan Marine Systems does not sell, ship or warrant products purchased outside the U.S.

HOW TO OBTAIN WARRANTY SERVICE

A WARRANTY REGISTRATION CARD MUST BE FILLED OUT AND RETURNED WITHIN 90 DAYS OF PURCHASE – FAILURE TO DO SO VOIDS THIS LIMITED WARRANTY. PLEASE COMPLETE A REGISTRATION CARD AT: www.rhodanmarine.com/warranty-registration/.

You are responsible for removing the Product from your vessel and returning the Product to a warranty service center (See list of centers at www.rhodanmarine.com/servicecenters) or to the Rhodan Marine Systems factory located in Sarasota, FL. Rhodan Marine Systems is not responsible for the removal or re- installation of the Product on your vessel. If the Product or any part is to be replaced, it must be returned to Rhodan Marine Systems before the replacement will be provided.

TO OBTAIN THIS LIMITED WARRANTY SERVICE

Please contact service@rhodanmarine.com or visit www.rhodanmarine.com/find-a-dealer/ to locate your nearest service center. Please include your name and serial number upon initial contact to expedite service. Follow the instructions provided to you.

DISCLAIMER OF IMPLIED WARRANTIES AND LIMITATION OF LIABILITY

TO THE EXTENT NOT PROHIBITED BY LAW. THIS WARRANTY IS EXCLUSIVE AND IN LIEU OF ALL OTHER WARRANTIES, ORAL, WRITTEN, STATUTORY, EXPRESS OR IMPLIED. EXCEPT FOR THE EXPRESS WARRANTIES CONTAINED IN THIS LIMITED WARRANTY STATEMENT AND TO THE EXTENT NOT PROHIBITED BY LAW, WE DISCLAIM ALL OTHER WARRANTIES, EXPRESSED OR IMPLIED, STATUTORY OR OTHERWISE, INCLUDING WITHOUT LIMITATION, THE WARRANTIES OF MERCHANTABILITY AND FITNESS FOR A PARTICULAR PURPOSE. SOME STATES DO NOT ALLOW DISCLAIMERS OF IMPLIED WARRANTIES, SO THIS DISCLAIMER MAY NOT APPLY TO YOU. TO THE EXTENT SUCH WARRANTIES CANNOT BE DISCLAIMED UNDER THE LAWS OF YOUR JURISDICTION, WE LIMIT THE DURATION AND REMEDIES OF SUCH WARRANTIES TO THE DURATION OF THIS EXPRESS LIMITED WARRANTY.

TO THE FULLEST EXTENT PERMITTED BY LAW, RHODAN MARINE SYSTEM'S

TOTAL LIABILITY UNDER THIS WARRANTY SHALL BE NO GREATER THAN THE AMOUNT OF THE ORIGINAL PURCHASE PRICE AND IN NO EVENT SHALL RHODAN MARIE SYSTEMS BE LIABLE FOR INCIDENTAL OR CONSEQUENTIAL DAMAGES OR LOSSES. THIS LIMITATION DOES NOT EXCLUDE LIABILITY FOR DEATH OR PERSONAL INJURY CAUSED BY RHODAN MARINE SYSTEMS' NEGLIGENCE.

GOVERNING LAW; JURISDICTION

This Limited Warranty is governed by the laws of the State of Florida (notwithstanding any conflict of laws provision). Any claim arising under this Limited Warranty shall be exclusively brought in the state of federal courts located in Sarasota County, Florida.

EXTENDED LIMITED WARRANTY TERMS

You may extend the Limited Warranty for 1 year beyond the expiration of the Limited Warranty by purchasing an Extended Limited Warranty. The Extended Limited Warranty must be purchased within 90 days of the date of original purchase of the Product. You will not be able to purchase an Extended Limited Warranty following the expiration of such 90-day period. The purchase price of the Extended Limited Warranty is 20% of our most recent published purchase price of the Product (same model number and size) at the time of purchase ("Extended Limited Warranty Purchase Price".) To purchase the Extended Limited Warranty, please click here: www.rhodanmarine.com/extendedwarranty.

If you purchase the Extended Limited Warranty, all terms of the Limited Warranty will continue to apply during the term of the Extended Limited Warranty except as otherwise described in the following additional Extended Limited Warranty Terms:

TERM OF EXTENDED LIMITED WARRANTY

1 year following the expiration of the Limited Warranty. The Extended Limited Warranty is not renewable.

WHAT IS COVERED

The coverage of the Limited Warranty continues for repair/replacement of the defective part only. The Extended Limited Warranty does not include the costs of shipping the Product to us and returning the Product to you. Shipping costs will be billed to you and are payable upon receipt of invoice. All shipping charges must be paid in full prior to the return of the Product to you.

CANCELLATION

You may not cancel your purchase of the Extended Limited Warranty. No refunds of the Extended Limited Warranty Purchase Price shall apply if you cancel.

We may cancel the Extended Limited Warranty for any reason by notifying you in writing at the address indicated on your Warranty Registration Card. The notice will state the effective date and reason for cancellation. If we cancel the Extended Limited Warranty, you will receive a pro rata refund of the Extended Limited Warranty Purchase Price based on the time remaining on the Extended Limited Warranty. We will pay the applicable refund within 30 days of our cancellation.



HDGPS ANCHOR+[®]

GPS Guided Trolling Motor



California Proposition 65 Warning
WARNING: This product contains chemicals known
to the State of California to cause cancer and birth
defects or other reproductive harm.
For more information: www.P65warnings.ca.gov

CUSTOMER SERVICE

Have your unit serial number ready and call
1-941-706-4578

RHODAN[®]
MARINE SYSTEMS

Rhodan Marine Systems
1290 Sarasota Center Blvd
Sarasota, Florida 34240